

REV.	DESCRIPTION	DATE	DRAWN	APPROVED
A1	DWG.REL	2015.3.12	FANG	YANG

- Material
 - ⊙Button : PA66, UL94V-0
 - ⊙Cover : PA66, UL94V-0
 - ⊙Housing : PA66, UL94V-0
 - ⊙Reed : Stainless steel
 - ⊙Pin header : Brass, Tin plated

- Electrical
 - UL IEC
 - Rated voltage : 300V 450V
 - Rated current : 7A 15A
 - Insulation resistance: 500MΩ/DC500V
 - Withstanding Voltage : AC2000V/1min
 - Wire range: 22-16AWG 1.5mm²

- Mechanical
 - Operating temperature: -40°C to +105°C
 - Soldering temperature: 250°C ±5/5sec
 - Strip length: 8-9mm

HOW TO ORDER

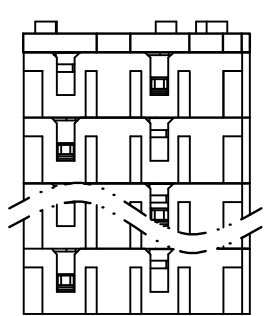
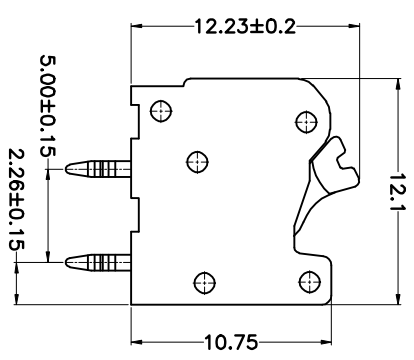
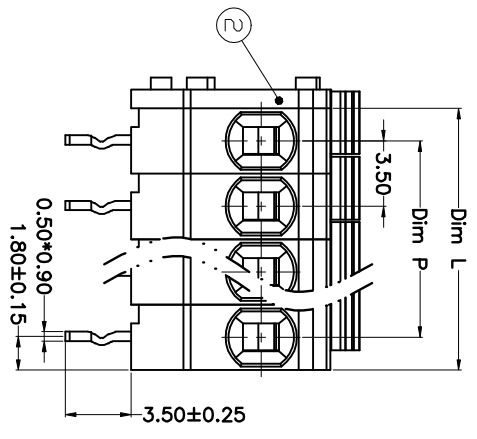
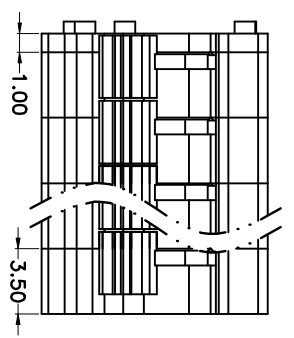
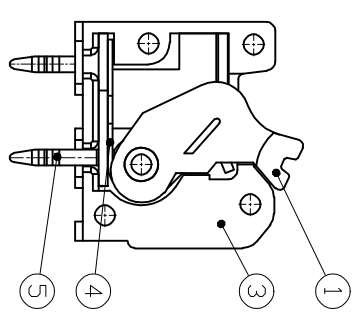
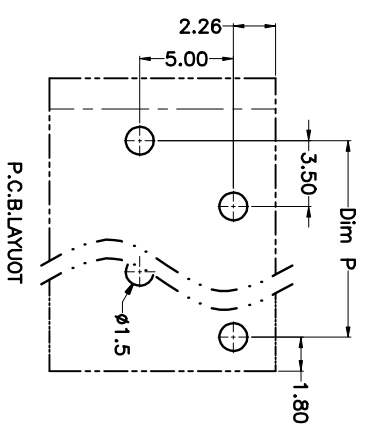
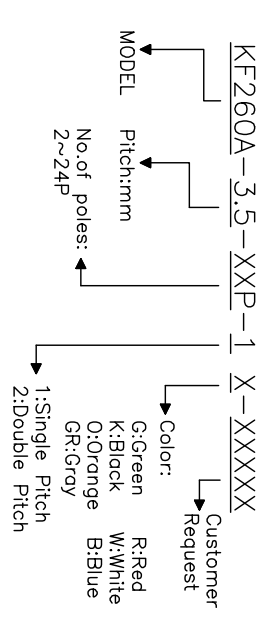

N=Number of Poles
Dim P=(N-1)x3.50
Dim L=Nx3.50

Poles	Dim P	Dim P	Dim L
2-6P	±0.10	±0.15	
7-12P	±0.20	±0.20	
13-18P	±0.25	±0.30	
19-24P	±0.30	±0.40	

GENERAL TOLERANCE	ANGLE TOLERANCE
X. ±0.5	X. ±5'
.X ±0.3	.X ±3'
.XX ±0.1	.XX ±1'

DRAWING TYPE	CUSTOMER
SCALE	1:1
SHEET	1 OF 1
DRAWING NO.	

PROJECTION	TITLE
UNITS	KF260A-3.5-XXP
SHEET SIZE	A4
SERIES	KF260A

科奕科技有限公司